



FAEBI® Product Description

Rubber air-spring for highly, effective insulation of machinery and sub-assemblies against impact and oscillation. The bell-shaped component is made of high-grade elastomer. The construction allows a highly effective insulation without the disadvantage of excessive horizontal deflection. It is impossible for the element to break down as a result of overloading or a sudden drop in pressure. To reduce vertical dampening, the component is available with additional attenuation. The baseplate is equipped with an anti-slip plate so there is no need to anchor the machine to the floor.

Note: For outdoor use (e.g. isolation of a roof top air condition unit) the FAEBI® can be supplied in **stainless steel** and **EPDM elastomer** version.

BILZ Level Controller Systems

Level control is important part of an optimally functioning air-spring system. Level control can be utilized whenever load changes occur on rubber air-spring insulated machines, causing an unwanted one-sided spring deflection of the air elements, e.g. tilting of the machine.

Insulation against Impact and Oscillation

Depending upon the static load, the natural frequency of the elements varies between to 2,5 – 6 Hz in vertical direction. The ratio between vertical and horizontal natural frequency is 1– 1,2. Maximum spring deflection during impulse load is approximately 15 mm.

Range of Application

Excellently suited for active insulation of high-speed power presses, forging hammers as well as other machines and equipment with high dynamic forces. Passive insulation of measuring and testing machines as well as high-precision machine tools.

Systems can also be supplied with an option of electronic or mechanical level control! (See page 21)

Assembly

The components are screwed on to the machine by means of pre-drilled holes. It is not necessary to anchor the machine to the floor. The machine is placed on deflated elements which are then inflated to a maximum of 5–6 bar via a standard valve. To level the machine, air can either be released or added. The maximum height adjustment available is 10 mm.

Control of Air Pressure

Upon request, FAEBI® elements can be equipped with an air pressure monitor. This monitor will indicate if air-pressure goes below the desired value.

FAEBI® 50
Load (daN)

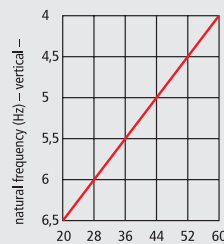

FAEBI® 75
Load (daN)

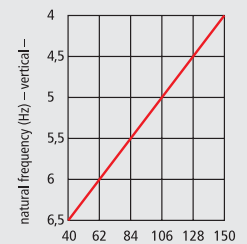

FAEBI® 100
Load (daN)

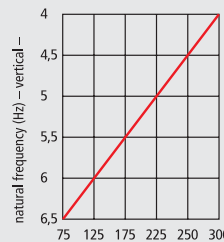

FAEBI® 125
Load (daN)

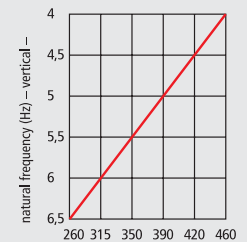

FAEBI® 150
Load (daN)

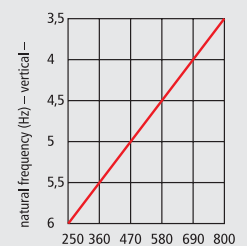

FAEBI® 200
Load (daN)

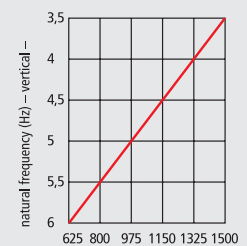

FAEBI® 300
Load (daN)

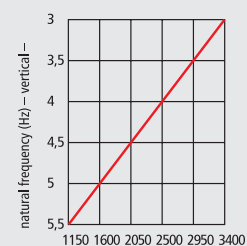

FAEBI® 430
Load (daN)

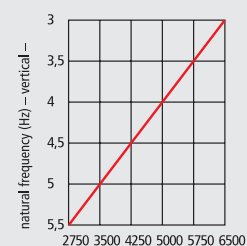

FAEBI® 580
Load (daN)

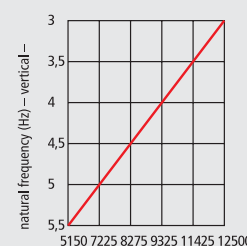



Combined Rubber-Airspring-Insulator
FAEBI®-HD with adjustable dampening

Rubber air-spring insulator FAEBI®-HD is made of a combination of high-grade elastomer and metal with an enlarged sidewall. In order to obtain as high a dampening effect as possible, the air space is split into two chambers (load / dampening volume) linked by an air pipe. By the adjustable valve the dampening can be changed easily from outside. Due to the friction caused by the air-stream passing through the bypass valve, it is possible to adapt the dampening to each application.

Because of the very high dampening, the resonance amplitude is much smaller and therefore you are able to achieve less machine movement. (see graph 1a + 1b) Furthermore the increased transformable energy takes effect on the production quality of your machinery.

Note:

In contrast to viscous dampers, the air dampening is absolutely wear-resistant and free of maintenance. Furthermore it is possible to change the dampening from outside.

Optional: FAEBI® mechanical-pneumatic control valves

The mechanical-pneumatic relief valves are a simple yet effective solution. The level is constantly scanned by a plunger. The plunger position is transmitted to a slide valve. Depending on the slide valve position, pressure is applied to the air spring or the inside pressure is reduced. The level can be maintained at an accuracy $\pm 1/10$ mm.

Principally three control valves are used. A pressure control valve to limit system pressure to a maximum of 6 bar, water trap to remove vapour and an air filter to remove dust and any foreign bodies from the air supply.

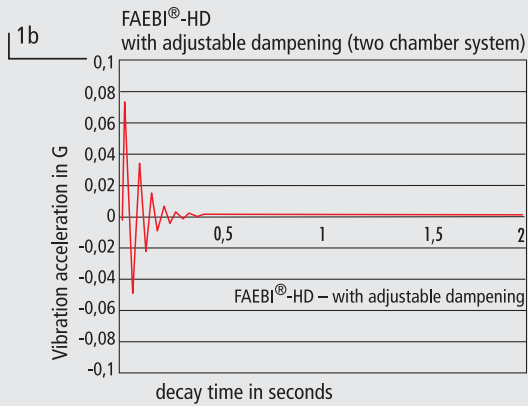
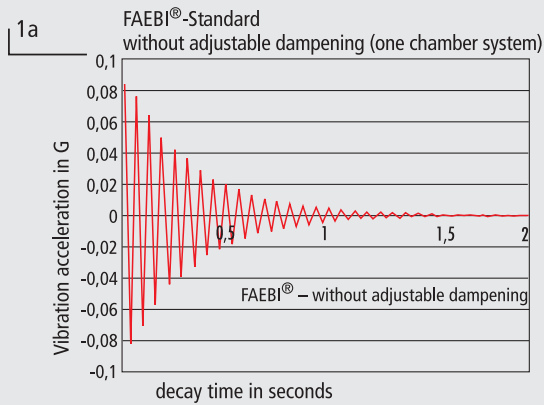

for shock and vibration insulation of machines, equipment and sub-assemblies

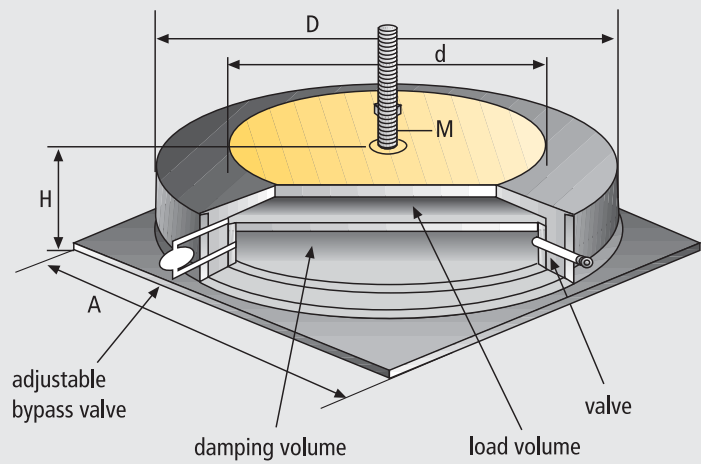

type	FAEBI® HD 200	load daN/pc.	625 - 1500	max. pressure / bar	6	A mm	260	D mm	236	H approx. mm = workheight	90	d mm	130	M	M 16
	FAEBI® HD 300		1150 - 3400		6		370		340		90		200		M 20
	FAEBI® HD 430		2750 - 6500		6		500		480		90		315		M 20
	FAEBI® HD 580		5150 - 12500		6		680		650		125		380		M 24

