

BiAir®



Zeiss measuring center mounted on BiAir®



BiAir®

Product Description

The Air-Spring Insulator **BiAir®** consists of a cast aluminum body whose air volume is enclosed by a thin-walled, flexible and pressure-resistant rolling diaphragm. The piston is seated on this diaphragm and is pushed into the air volume.

This design causes highly effective vibration insulation.

In order to obtain as high a dampening effect as possible, the air space is split into two chambers (load/dampening volume) linked by air pipe. By the adjustable valve the dampening can be easily changed from outside. Due to the friction caused by the air-stream passing through the bypass valve, up to 20% dampening can be effected. Additional safety valves will protect the roller diaphragm from getting damaged by over-inflation.

Range of Application

Highly effective vibration insulation of sensitive measuring and testing machines, fine-machining plant, as well as optical and electronic equipment. Another important range of application is the vibration-insulated foundation of vehicle, motor and other performance testers. **BiAir®** Air-Spring insulators are extremely well suited for the insulation of foundations e.g. equivalent machine loads.

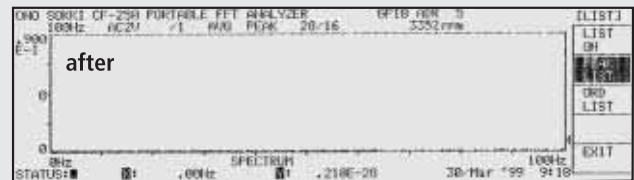
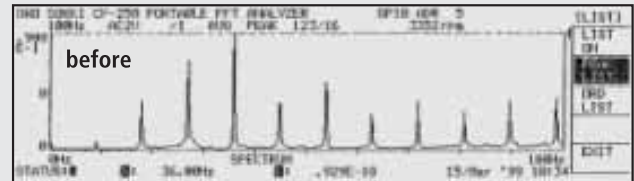

Advantages compared with conventional steel springs

BiAir® Air-Spring insulators with level control are an active system. The machine/foundation level consistency will always be preserved! Automatic leveling/adjustment!

BILZ level controller systems

Level control is an important part of an optimally functioning air spring system. The automatic level controller can be utilized to overcome the problem associated with load changes in air-spring insulated machines, which can result in tilting of the machine.

The height of the specific elements **BiAir®** or **FAEBI®** can be controlled by changing the air pressure in the air-spring insulators. Quick inflation or deflation will hold the machines level even if their center of gravity keeps changing.

Control circuit

The circuit consists of at least three air springs. If more air springs are needed for structural or loading reasons, the system must always include 3 position pickups, e.g. three controlled components in order to avoid statical overdefinition. This is achieved by connecting sets of air springs in parallel.

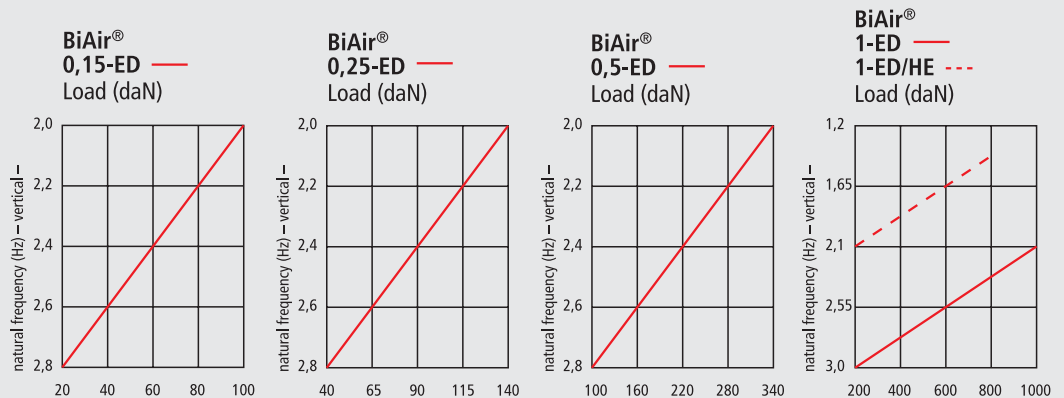

with deep natural frequency and adjustable dampening (pat.)
for vibration insulation of measuring and testing machines,
optical and electronic equipment, laser machines,
fine machining plant, vehicle and motor performance testers etc.

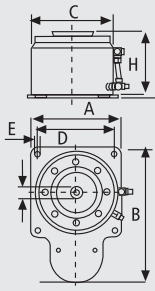

type	BiAir 0,15-ED-ST	BiAir 0,25-ED-ST	BiAir 0,5 -ED-ST	BiAir 1 -ED-ST	BiAir 2 -ED-ST	BiAir 2,5 -ED-ST
Ø A mm	76	110	130	200	260	300
width W mm	72	182	190	275	350	390
Ø C mm	72	110	129	200	260	300
workheight H mm	77	87	100	100	100	100
max. load daN at max. 4 bar	67	113	267	633	1420	1967
max. load daN at max. 6 bar	100	170	400	950	2130	2950
natural frequency Hz (vertical) approx.	2,5	2,5	2,5	2,5	2,5	2,5
natural frequency Hz (horizontale) approx.	2,5	2,5	2,5	2,5	2,5	2,5

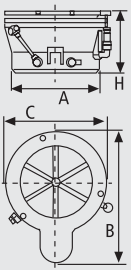

BiAir 0,5-ED	120	216	129	157	267	400	2,5	2,5
BiAir 1 -ED	172	288	200	157	633	950	2,5	2,5
BiAir 2 -ED	226	335	260	157	1420	2130	2,5	2,5
BiAir 2,5-ED	271	378	300	157	1967	2950	2,5	2,5
BiAir 3 -ED	348	467	382	157	3413	5120	2,5	2,5
BiAir 4 -ED	490	605	530	157	6573	9860	2,5	2,5
BiAir 5 -ED	747	855	798	157	15573	23360	2,5	2,5

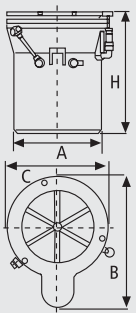

BiAir 1- ED/HE	172	288	200	307	633	950	1,5	2,5
BiAir 2- ED/HE	226	335	260	307	1420	2130	1,5	2,5
BiAir 2,5-ED/HE	271	378	300	307	1967	2950	1,5	2,5
BiAir 3 -ED/HE	348	467	382	307	3413	5120	1,5	2,5
BiAir 4 -ED/HE	490	605	530	307	6573	9860	1,5	2,5

ST = Steel

When choosing the size of the air-spring consider loading at 4 bar only.

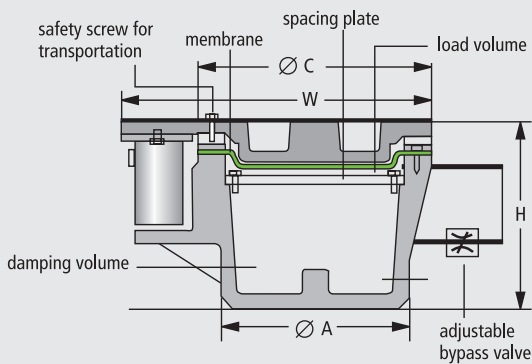

Air springs with higher max. loads as well as air springs with lower natural frequencies can be supplied upon request!

BiAir®
2-ED ——— Load (daN)
2-ED/HE - - - - -

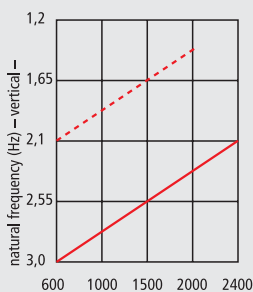

BiAir®
2,5-ED ——— Load (daN)
2,5-ED/HE - - - - -

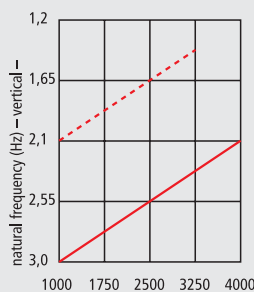

BiAir®
3-ED ——— Load (daN)
3-ED/HE - - - - -

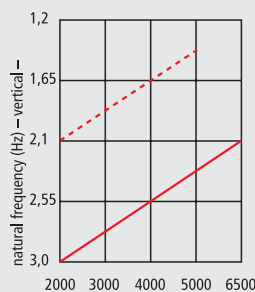

BiAir®
4-ED ——— Load (daN)
4-ED/HE - - - - -

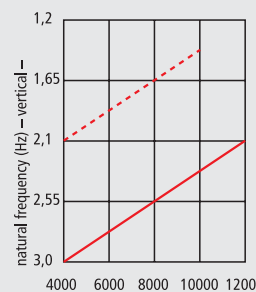

BiAir®
5-ED ——— Load (daN)

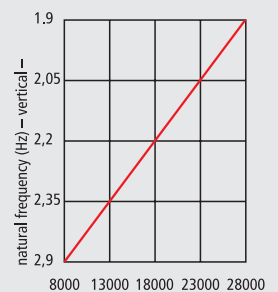



BiAir® MPN

BiAir® mechanical-pneumatic positioner/controller

The mechanical-pneumatic relief valves are a simple yet effective solution. The level is constantly scanned by a plunger. The plunger position is transmitted to a spool valve. Depending on the spool valve position, pressure is either applied to the air spring or vented from the inside of the air spring. The machine level can be maintained at an accuracy $\pm 1/100$ mm.

Principally three control valves are used. The incoming air supply is conditioned with a pressure regulator to limit system pressure to a maximum of 6 bar and with a water trap to remove vapor and an air filter to remove dust and any foreign bodies from the air supply.



BiAir® EPN

BiAir® electro-pneumatic positioner/controller

Advantages

Important advantages of the BILZ level control are:

- a high reset accuracy e.g. level accuracy of $\pm 1/100$ mm
- extremely short reaction time (within the milli-second range)
- the general possibility of being able to optimally adapt (increase and reset) the speed of the system to the specific conditions (control circuit)
- wear-resistant and sturdy relief valves
- simple and effective set-up operation

System components

Each system consists of 3 position sensors, 3 electro-pneumatically relief valves, one control unit (digital computer logic), the air-supply regulator and filter units.

Even the most severe conditions are mastered by the electro-pneumatically positioner. It is used mainly where high reset precision and extremely short reaction times are required.

Any deviation (difference between desired value and actual value) from the desired height (desired value) of the air spring insulators is measured at a precision of up to $1/100$ mm accuracy by means of position sensors.

In the control unit, these electronic signals will then be processed and the air spring elements will be inflated or deflated accordingly for level equalisation via the pneumatic relief valves.

Control unit

The control unit consists of a printed circuit board, containing the entire logic of the 3 control circuits, 3 air pressure displays for the air springs, adjusting screws for the adjustment of the machine, selection of the controller speed, and a switch to enable complete deflation of the air springs. The control unit can be supplied either as a 19 inch rack mount unit or completely enclosed within a cabinet.

Software

As an optional feature, a special software package is available. By means of this software, the adjustment and optimization of controlled conditions, the registration of adjustment parameters as well as error determination can be carried out via the serial interface (serial interface provided on the control unit).

Furthermore, the integrated serial interface enables link-ups with available machine computers or systems to be insulated. A number of more complex system modes can be realized this way.